

REV	DESCRIPTION	DRAWN	DATE

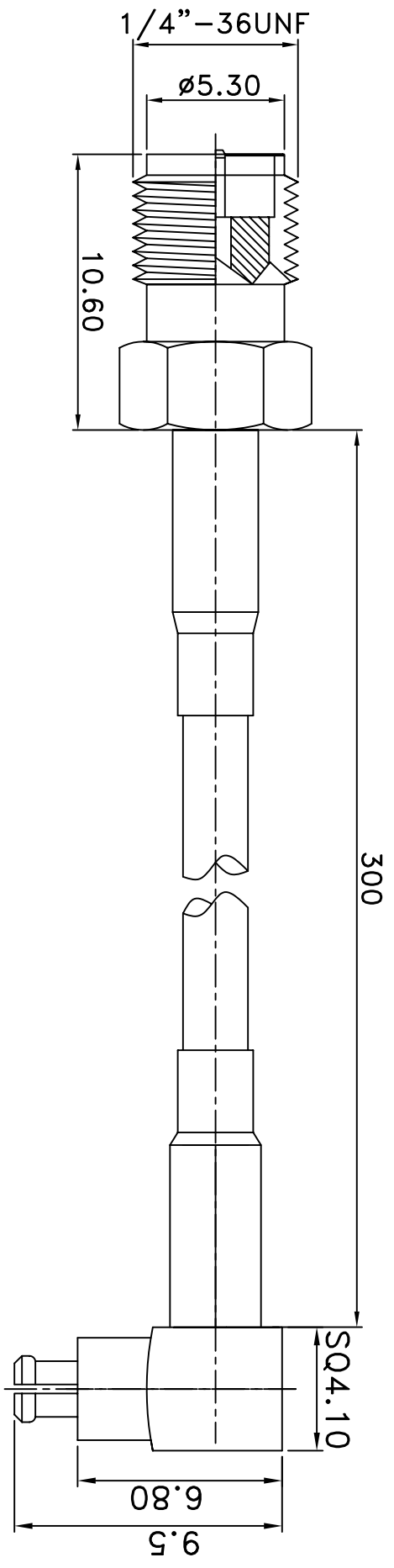

NO	Description	Qty	Material	Finish
3	MC CARD-2501-3-L-TGN	1	BRASS	NICKEL
2	LOW LOSS 100	1		
1	SMA-1011-2-L-RP-TGG	1	BRASS	GOLD

1 REMOVE ALL BURRS 2 BREAK ALL CORNERS & EDGES CO.15 MAX. 3 CHAMFER 1ST & LAST THREADS 45°. 4 DIAMETERS ON COMMON CENTERS TO BE CONCENTRIC WITH DIMENSIONS ARE AFTER PLATING.		* MAJOR DIMENSION UNLESS OTHERWISE NOTED TOLERANCES 0.5-6 = ±0.2 6-30 = ±0.4 30-120 = ±0.6 120-315 = ±1.0 ANGLES = ±1°		APPROVED CHECKED DRAWN CHAI		TITLE SMA1011-MC CARD DRAWING NO. 10112R100MC CARD-1300 FILE NO. D:\DWG\SMA1011-MC CARD\10112R100MC CARD-1300	
SCALE	4/1	UNIT	MM	DRAWN DATE	06/16/16	REV	A

