

Model HT-322 Coax Stripping Tool

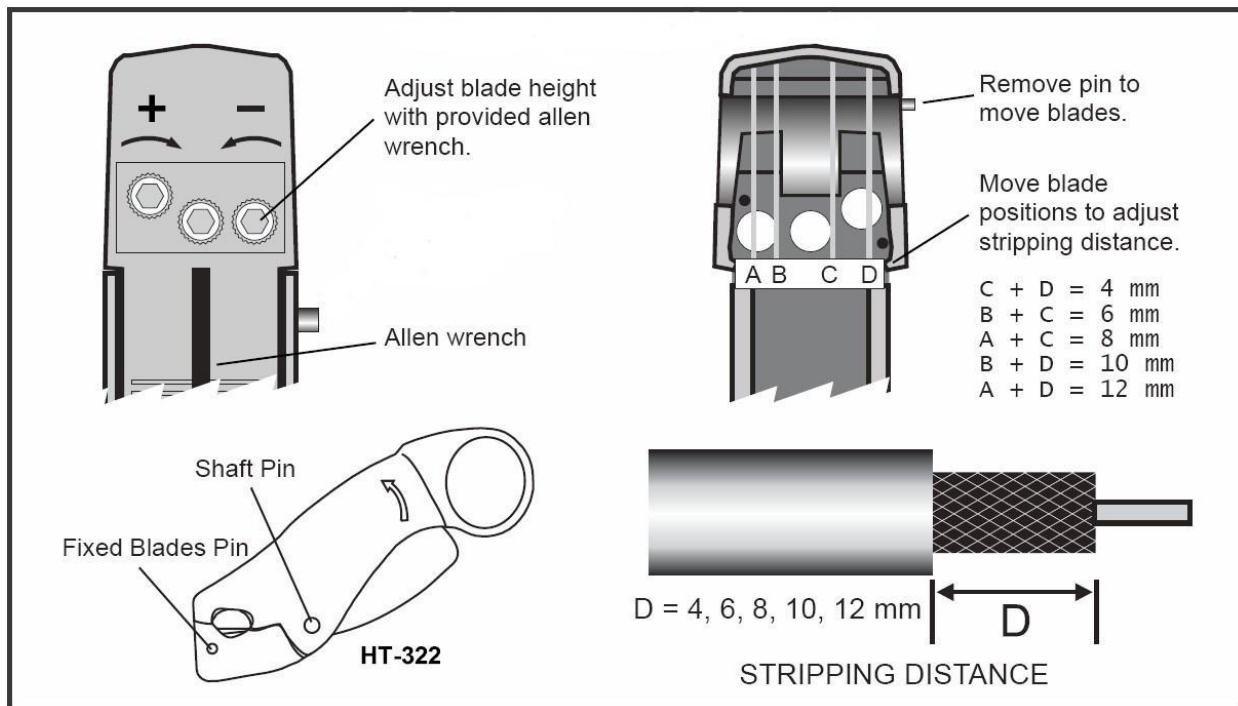

Model HT-322S 2-blade (A & C)

This stripping tool is compatible with LMR400 (or equivalent) type cable and RG8/11/213.

Model HT-322 3-blade (A, C & D)

This stripping tool is compatible with LMR195/200 (or equivalent) type cable and RG6/58/59.

Minor blade adjustments may be required for proper blade height.